

NOTE:ALL MATERIAL COMPLIANT ROHS STANDARD

Unit package
 Size: 6 * 6 * 27.5
 Weight: 0.77 LBS



REVISION INFORMATION			
Rev.	Rev.Date	Modified By	Brief Description

SIDE MARK (TWO SIDES)

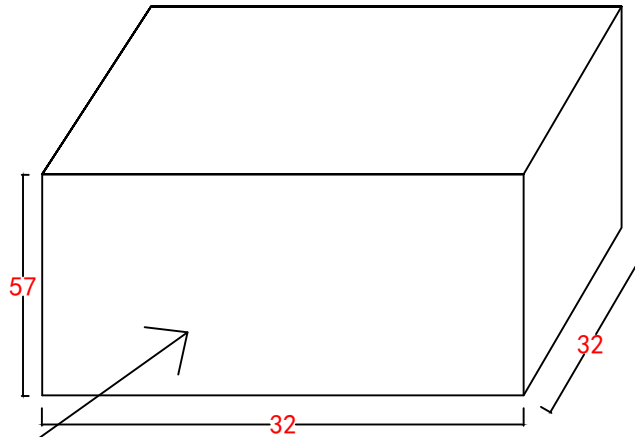

P/N: 210938
 Q'TY: 50 pcs
 N.W: 17.5 KGS
 G.W: 18.5 KGS
 Date Code: 28-2017
 Vender Code: PS01220

MAIN MARK (TWO SIDES)

P/O: 1700769
 P/N: 210938
 Q'TY: 50PCS
 C/NO: C01...

MADE IN CHINA

Carton Size: 32 * 32 * 57
 Carton Quantity: 50 pcs
 Carton Weight: 40.7 LBS

DRAWN BY	DATE: 2017.06.17	DESCRIPTION: 60L 5mm LED Star light 30cm (12") Open Dia IP44 Outdoor AC Powered
CHECKED BY	SHEET 1 of 1	ITEM NO. 210938
APPROVED BY	SCALE 1:1	REV.00 UNIT:cm

③				
②				
①				
NO.	PART NAME	SPECIFICATION DESCRIPTION	QTY	UNIT